

ACCURL CNC PRESS BRAKE

EURO GENIUS SERIES

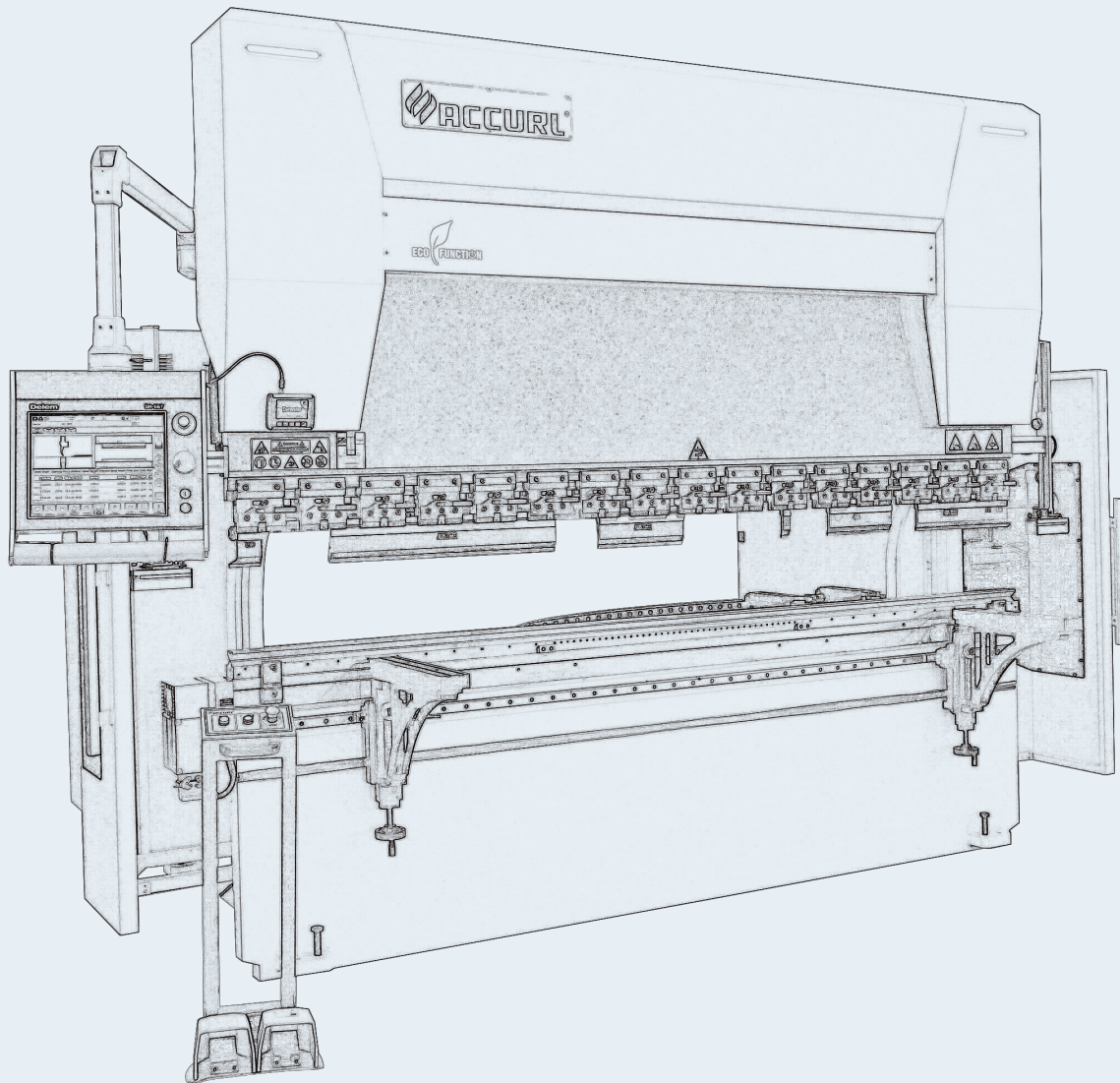

 **ACCURL**[®]

Shaping your future

ACCURL GENIUS CNC PRESS BRAKE EURO-GENIUS B SERIES

ACCURL® EURO-GENIUS Series press brake features an CNC crowning system for improved quality, a servo driven back gauge system for increased speeds, and 3D capable graphical control unit to simulate bending sequences and collision points. Also has increased working speeds, stroke, daylight, and pressing capacities of GENIUS Series machines.

The future - as a result of rising energy costs and increasingly cost efficient speed-controlled drives offered on the market, variable-speed solutions are on the advance.



High Capacity

Robust Body

Perfect Precision

Energy Saver

Ergonomic

Precise bending result at fast speed

Minimalized tool change and adjustment time

Maximized speed and safety



ADVANTAGES

- High energy-saving potential
- Decreased operating costs
- Clearly reduced cooling effort
- System safety
- Future-oriented technology
- Remarkable noise reduction
- Fewer secondary measures
- Compliance with EU CE Directives
- Decrease in the number of expensive machine failures

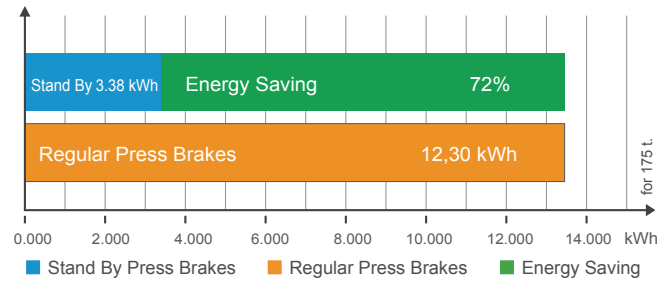

STANDARD EQUIPMENT

- DELEM DA-66T CNC control unit with 2D graphics
- 5 axis CNC:
- Y1, Y2 precision ram positioning
- Standard BGA-2 for X, R-axis (X=800mm,R=200mm)
- CNC motorized wave crowning
- Large trio of value:
- Large open height
- Large stroke
- Large throat depth
- HOERBIGER hydraulic valve block, pump and valves
- High Siemens efficiency motor– class IE3
- Stand By Function for energy-saving drive.
- Rear cover: Safety barriers (Category IV)
- Sheet metal frontal supports
- Front and rear lighting
- Offline software Delem Profile-TL
- Front cover: AKAS LC-II F safety laser (Category IV) or DSP safety

OPTIONAL EQUIPMENT

- Control unit – DELEM DA69T or ModEva Premium
- CE Defender LazerSafe LZS004 + safety covers with switch
- CE F. AKAS-LC II AKAS-3 M Motorized + FPSC (safety PLC)
- BGA-4 for X ,R , Z1, Z2 axis
- BGA-6 for X 1, X2, R 1 , R2 ,Z1, Z2 axis
- Delta X5 axis ± 125 mm with CNC Controlled
- X axis = 1000 mm – light barrier back protection
- AP3-AP4 sheet following system
- Height adjustable laser angle measurement system
- Hydraulic and pneumatic tool clamping systems
- Additional back gauge finger and sliding front support arms

HYDRAULIC SYSTEM

ACCURL is composed of the most evolved version of the valves (AMB model), The HOERBIGER has perfected the integration of hydraulic components in the system. integrated the pump, pressure filter and pressure adjustment of the performance module are combined in one control block.

Advanced with Perfection:

- Compact system design
- Substantially reduced noise level
- Can be directly flanged to standard motors



HOERBIGER



The power module PLM combines pump, pressure filter and pressure adjustment in a bell housing developed as a control block. The low-noise high-pressure internal gear pump, from 5 to 50 ccm/r.

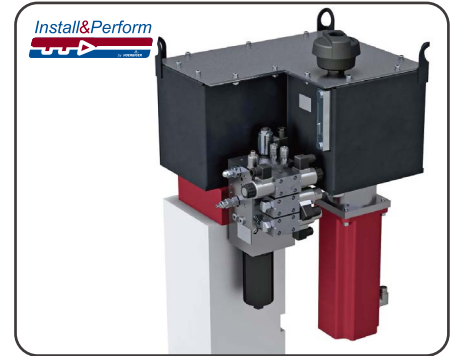

The new control valves type PIH/PRH in combination with our system amplifier PVR permit load-independent positioning of CNC press axes within a few μm .



ePrAX® control - THE Servo Drive (Optional)

- All valves and pressure filter at one, in the system integrated, control block.
- Up to 5 μm positioning accuracy (with cylinder/servo seals)
- Small tank (2 x 35 Liter).
- No external piping / tubing.
- Pump and prefill valve inside tank
- simple cylinder interface

STAND-BY-ECO FUNCTION

ACCURL® promotes a friendly environmental policy and as such, all our equipment features the Standby Function. ECO-Standby Function ensures an Active economy of energy on an automatic basis.



Stand-By-ECO CNC Genius Press Brake provides energy saving up to 50%

Genius CNC Press Brake has 50% energy saving compared with hydraulic press brakes.



Stand-By-ECO CNC Press Brake provides high productivity

Stand-By-ECO has high acceleration, high deceleration. The quick change of the moving direction is an advantage for high productivity and efficiency and has less maintenance cost.



Stand-By-ECO Press Brake is ECO - friendly machine

The STAND-BY combines high accuracy, flexibility and reliability, this concept offers low power consumption, less maintenance.



Stand-By-ECO CNC Press Brake works quietly

Stand-By working system has no noise and provides silently working conditions.

CONTROL SYSTEM

DELEM	Axes	Screen	2D graphic view	3D graphic view	3D graphical programming	Automatic bending sequence	Touch screen	DXF import	CYBELEC
DA-66T (standard)	8	17"	✓	✓	X	✓	✓	○	ModEva 15T
	8	15"	✓	✓	X	✓	✓	X	
DA-69T	8	17"	✓	✓	✓	✓	✓	✓	ModEva RA
	8	15"	✓	✓	✓	✓	✓	✓	

✓ Available

X Unavailable

○ Optional

Delem

CYBELEC
INFRANOR GROUP COMPANY



DA-66T



ModEva 15T



DA-69T



ModEva RA

PROFILE-T OFFLINE 2D/3D SOFTWARE (OPTIONAL)

Offline Programming

DA-Offline software maximises machine efficiency and production output of press brakes. The Profile T software facilitates offline programming and simulation the bending process. Production preparation, makeability and tooling verification, operator training, adding notes for production and many other functions can be carried out offline.

The Profile T software offers advanced programming in 2D/3D in line with the DA-Touch controller software. The steps from the start of programming to the desired program including its transfer to the control are clearly embedded in the user interface. Programming the product graphically shows a true scale representation of the intended product. Realistic product visualisation gives feedback on feasibility, collisions, required tools and tool adapters for production.

Profile-T features:

- 2D or 3D versions
- DXF converter (3D version only)
- Full scale offline programming
- Graphical product programming and bend sequence generation
- Feasibility studies and production preparation
- 2D/3D automatic bend sequence calculation
- Collision detection
- Product sharing over Windows networking with press brake CNC
- Machine setup preparation including print functionality
- Production time calculation

Delem

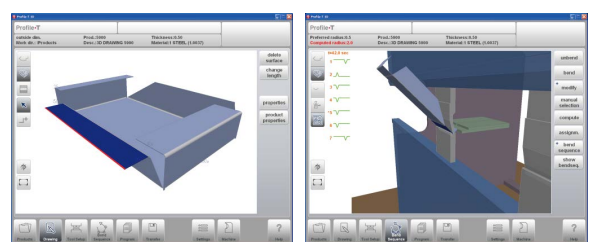
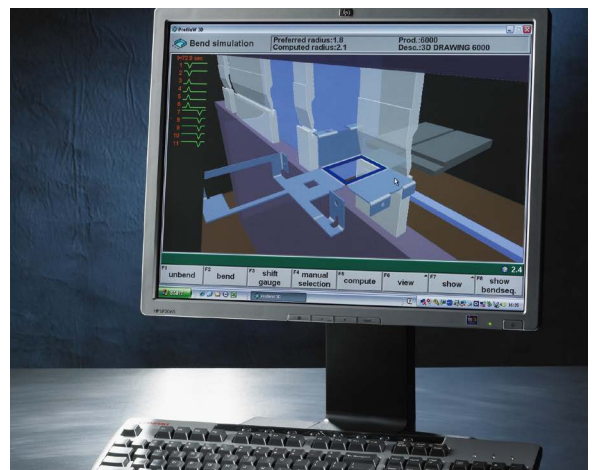

ROLLERI PNEUMATIC CLAMPING SYSTEMS ROL200(OPTIONAL)

The New ROLLERO clamping ROL200 system enables manual, pneumatic or hydraulic vertical clamping of your top tools. The special features are the enormously simple handling and the surprisingly low price, which guarantees huge efficiency.

- fast vertical tool change for all Roller R1 type punches
- safe and fast tool change
- substantial improvement in time consumption and related costs
- Secure against tool falling down
- Available in manual, pneumatic and hydraulic models
- Mounting: Simply from the bottom into the housing, tighten-DONE!
- Easy to mount on your press brake. Modification of the press brake is not necessary

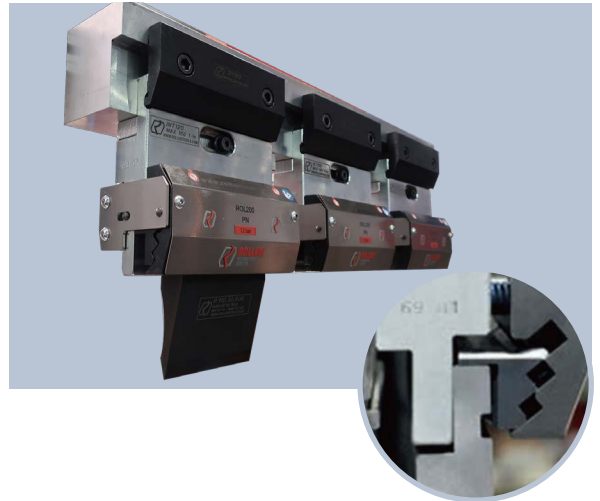

WILA NEW STANDARD AND CLAMPING SYSTEMS (OPTIONAL)

Innovative and super-fast clamping systems for clamping punches to the upper beams of press brakes. The Universal Press Brake Concept (UPB) makes it possible to install New Standard and Clamping Systems on any press brake.

The advantages:

- Extremely fast press brake tooling changes
- Extremely accurate clamping, positioning and alignment
- Individual clamping pins for each tool segment for superior clamping force
- Vertical and horizontal tool loading and unloading for maximum speed and safety
- Professional finish, including a slide rule for ease of tool positioning
- Provides maximum productivity when used in combination with WILA Tooling



WILA NEW STANDARD CROWANG AND HOLDERS (OPTIONAL)

WILA Crowning systems fully compensate for the deflection in press brakes. This results in a consistent bending angle across the entire length of the machine. WILA New Standard Crowning Systems utilize a series of patented adjustable wedges known as Wila Waves.



The advantages:

- Always provides an extremely consistent bending angle
- Available with automatic or manual drive systems
- Mounted on the right-hand side as standard
- Aluminum Cover strip with integrated slide rule for exact tool positioning
- Compact design which is practically maintenance free

CNC BACKGAUGE

ACCURL press brake are provided are equipped with a backgauge constituted by a solid structure in order to assure the best repetitiveness and high precision in axes positioning.

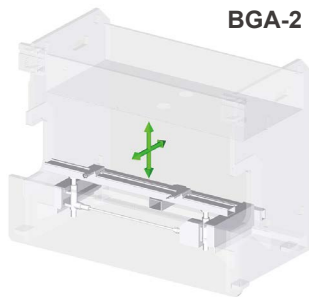

2 axes Y1-Y2-X-R

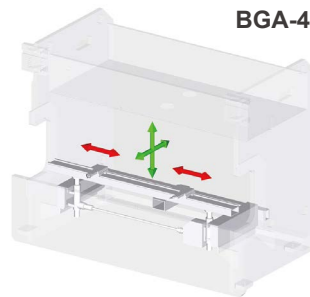

4 axes Y1-Y2-X-R-Z1-Z2

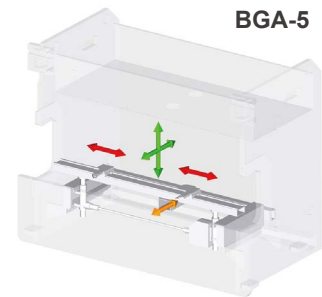

5 axes Y1-Y2-X1-R-X5-Z1-Z2

/ BGA

		Axes	X	R	Z1	Z2	X5
BGA 2	2 axes X+R (Standard)						
		Stroke (mm)	750 (1000)	150	Under request*	Under request*	190
BGA 4	4 axes X+R+Z1+Z2 (Optional)						
		Speed (mm/s)	500	170	2000	2000	300
		Precision (mm)	0.01	0.05	0.05	0.05	0.01
BGA 5	5 axes X+R+Z1+Z2+X2 (Optional)						
		Type of motor	Servo Drive	Servo Drive	Servo Drive	Servo Drive	Servo Drive
		Mechanical system	Ball screw	Ball screw	Rack	Rack	Ball screw

/ BGA 6

X1 - X2, R1 - R2, Z1 - Z2

Precise

Reliable

Strong

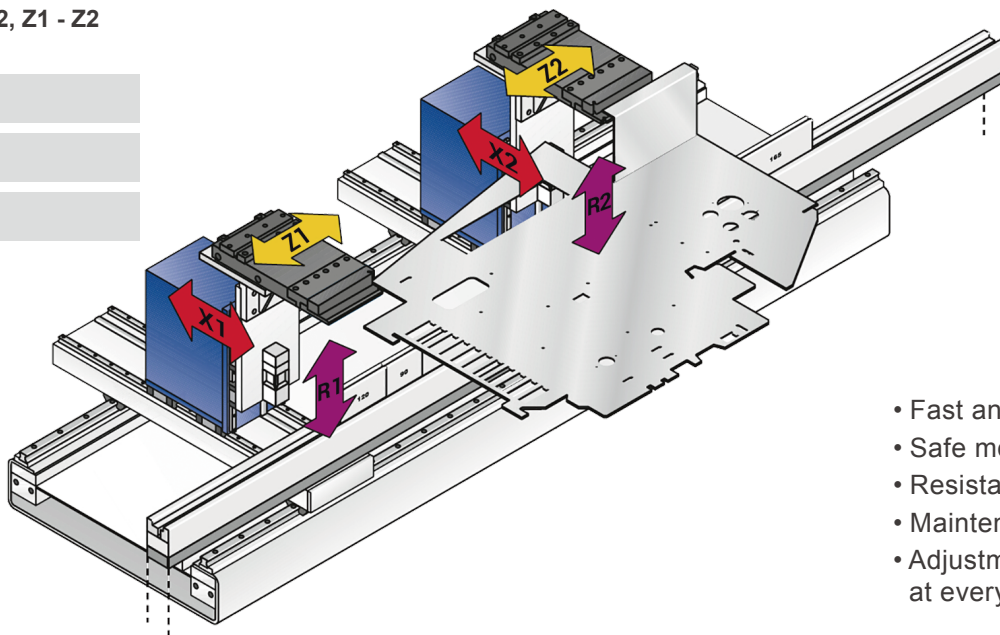

- Fast and high accuracy
- Safe movement
- Resistance to crash
- Maintenance free
- Adjustment availability at every point

Axes	X1	X2	R1	R2	Z1	Z2
Stroke (mm)	750	750	200	200	Under request*	Under request*
Speed (mm/s)	500	500	500	500	2200	2200
Accuracy (mm)	0.01	0.01	0.01	0.01	0.05	0.05
Type of motor	Servo Drive	Servo Drive	Servo Drive	Servo Drive	Servo Drive	Servo Drive
Mechanical system	Ball screw	Ball screw	Ball screw	Ball screw	Rack	Rack

LAZERSAFE SYSTEM (OPTIONAL)

ACCURL machines comply with the strictest EU regulations with reference to safety. The devices installed guarantee thorough safety of the operator without reducing the pace of work.

- The most advanced laser systems
- Safety PLCs able to manage and monitor the action of the proportional valves
- Visible dual beam linked to the upper tool: should it be interrupted, it blocks the movement of the press brake
- Easy adjustment by means of a grading scale
- Constant monitoring of parameters related to safety

IRIS

The best in terms of safety: working cycles are faster thanks to the speed change at 0mm from the contact with the sheet. The speed management is determined by the processed parts.

IRIS PLUS

Speed and precision: the speed change is set at 0mm from the contact with the sheet and the angle control system ensures high quality results from the first bend.

Final Angle Confirmation

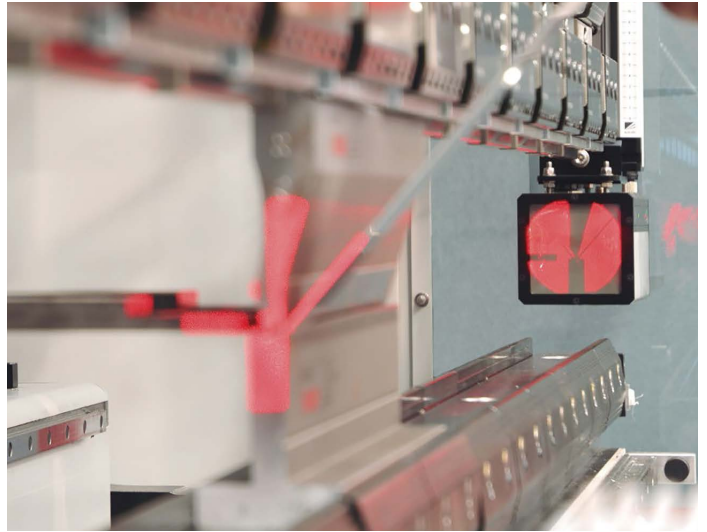

Final Angle Confirmation is a function where, during decompression, IRIS processes real time images to automatically detect the material relaxation point and measure the final bend angle.

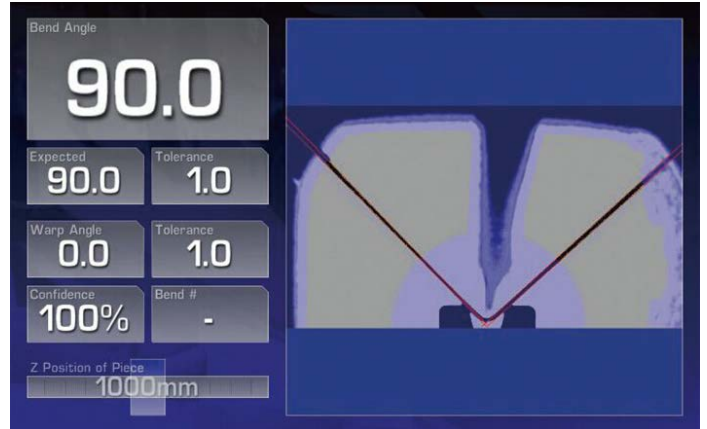

IRIS Model Comparison

	IRIS	IRIS Plus
Optical range (metres)	8m	4m
Bend Speed management	●	●
Active Angle Control		●
Dynamic Angle Control		●
Spring Back Calculation		●
Final Angle Confirmation		●



Model	Type	St Op	Distance from table	Automatic adjustment	Fast bend speed management	Automatic Tool Scan
 LZS-LG-HS	Dual Laser	○	6 mm	X	X	X
 LZS-005	Block Laser / Camera	○	2 mm	X	X	✓
 IMG-100	Block Laser / Camera	○	2 mm	X	✓	✓

✓ Yes X No-Standard ○ Optional

AUTOMATIC CROWING SYSTEM

This system enables the user to offset deformations of the beam while bending. Thus, the angle is keeping constant along the entire plate length.

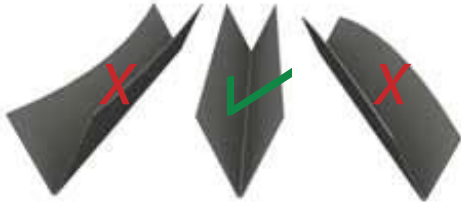

Exaggerated to Demonstrate



SMART-FAB comes standard with manual or optional CNC crowning
EURO-PRO comes standard with CNC crowning



SPECIFICATIONS

Type	Bending Length mm	Bending Capacity KN	Throat Depth mm	Daylight Opening mm	Stroke mm	Fast Approach Speed mm/s	Max. Bending Speed mm/s	Return Speed mm/s	Motor Power kw	Length+/- mm	Width+/- mm	Height+/- mm	Weight+/- kg	Backgauge stroke mm
EURO GENIUS B25110H	2500	1100	450	550	300	200	0-10	180	7.5	3650	1800	2830	8000	800
EURO GENIUS B32110H	3200	1100	450	550	300	200	0-10	180	7.5	4280	1550	2960	8900	800
EURO GENIUS B32135H	3200	1350	450	550	300	200	0-10	180	11	3880	1860	2960	9500	800
EURO GENIUS B40135H	4000	1350	450	550	300	190	0-10	160	11	4880	1860	2970	11000	800
EURO GENIUS B32175H	3200	1750	450	550	300	190	0-10	160	15	4290	1780	3000	11500	800
EURO GENIUS B40175H	4000	1750	450	550	300	180	0-10	160	15	4900	1900	3020	12650	800
EURO GENIUS B60175H	6000	1750	450	550	300	160	0-10	160	15	6900	2000	3380	19700	800
EURO GENIUS B32220H	3200	2200	450	550	300	180	0-10	150	18.5	4320	1930	3240	13500	800
EURO GENIUS B40220H	4000	2200	450	580	320	165	0-10	150	18.5	4920	1930	3250	14950	1000
EURO GENIUS B60220H	6000	2200	450	580	320	160	0-10	140	18	6920	2050	3380	23000	1000
EURO GENIUS B32250H	3200	2500	450	600	350	160	0-10	110	22	4350	2020	3280	17300	800
EURO GENIUS B40250H	4000	2500	450	600	350	150	0-10	110	22	4950	2020	3290	19300	1000
EURO GENIUS B32320H	3200	3200	450	630	350	150	0-10	110	30	4450	2020	3380	19500	800
EURO GENIUS B40320H	4000	3200	450	630	350	130	0-10	110	30	4960	2020	3390	21800	1000
EURO GENIUS B60320H	6000	3200	450	630	350	130	0-10	100	30	7000	2100	3580	33000	1000
EURO GENIUS B40400H	4000	4000	500	630	350	130	0-10	100	37	4980	2300	3590	28500	1000



This catalog is not a contractual document and only for illustrative purposes.
ACCURL reserves the right to modify any specifications within this catalog without prior notice.

ACCURL.BLUELIN E.E/11.2017